

# 100100B X-RAY INSPECTION

Explosives, Weapons and Contraband

SINGLE SOURCE, MULTI-ENERGY

X-RAY INSPECTION



The 100100B direct transmission X-ray system features a raised conveyor that enables sharper, larger screen images while making loading and offloading easier. This heavy-duty conveyORIZED scanner is designed for screening large objects, hold baggage and cargo for concealed weapons, explosives and contraband. Multi-energy color allows operators to quickly spot areas of concern in the most thickly packed parcels, bulk loads and baggage.

- > Ideal for inspecting oversized and out-of-gauge objects
- > Produces larger, more detailed images
- > Excels in high throughput applications

#### APPLICATIONS:

- > Airports
- > Courts
- > Customs
- > Loading Docks
- > Mailrooms
- > Rail or Bus Stations
- > Government Buildings

# 100100B SPECIFICATIONS

X-RAY INSPECTION

## PHYSICAL DETAILS

<b>Tunnel Size:</b>	100.0 x 100.0 cm 39.4 x 39.4 in. (W x H)
<b>Dimensions:</b>	314.2 x 129.3 x 192.9 cm 123.7 x 50.9 x 75.9 in. (L x W x H)
<b>Weight:</b>	726 kg (1,600 lbs.) uncrated 998 kg (2,200 lbs.) crated
<b>Construction:</b>	Unibody heavy gauge epoxy painted steel construction with stainless steel and aluminum trim and accessories; non-marking casters
<b>Temperature:</b>	0° to 40°C (32° to 104°F)
<b>Humidity:</b>	20% to 95%, non-condensing
<b>Storage:</b>	To 65°C (149°F)
<b>Power Consumption:</b>	< 0.7 kVA; < 7.5 amps 100, 110 volts AC ±10%; < 3.75 amps 200, 220, 240, 250 volts; all at 50 or 60 Hz

## X-RAY GENERATOR

<b>X-ray Tube Head:</b>	Self-contained
<b>High Voltage Rating:</b>	160 kV
<b>Duty Cycle:</b>	100% with sealed oil bath cooling
<b>Beam Orientation:</b>	Diagonal (80° beam divergence)
<b>Dose Per Exam:</b>	0.1 mR

## INSPECTION CAPABILITIES

<b>Material Penetration:</b>	28–29 mm (1.10–1.14 in.) steel
<b>Contrast Sensitivity:</b>	Over 2 million color tones standard
<b>Resolution:</b>	40 AWG wire
<b>Processing:</b>	32-bit adaptive image processing with minimum 1 Gbytes+ memory; 2.2GHz or 2.4 GHz+ dual core processor; video processing using next generation graphical processing unit architecture with 550MHz+ GPU clock, 512Mbyte+ video memory and 32+ stream processing cores
<b>Conveyor Speed:</b>	24.0 cm (9.4 in.) per second 14.6 m (48 ft.) per minute
<b>Pulling Weight:</b>	150 kg (331 lbs.)
<b>Film Safety:</b>	Guaranteed for high-speed film up to ISO 1600 (33 DIN)

## DETECTORS

L-shaped detector for 100% object screening  
Surface mounted, multilayer, fully integrated, high frequency solid state detectors using high speed processors and Pentium 4 image processing

## VIDEO

Color 19" monitor, 1280 x 1024 video card

## STANDARD FEATURES

- autoSoft operating system
- Full-size operator control panel (OCP) with touchpad navigation
- autoTracking guided conveyor belt system
- Reversible conveyor direction
- High/low density and stripping
- Organic/inorganic stripping
- Color; reverse B/W imaging
- Interactive, user-friendly help screens
- 128x Smart Zoom
- D-SCAN
- Dark and light enhance
- autoImage recall (10 images)
- RealClear
- autoDensAlert
- autoOutline
- autoSensing
- Z-SCAN
- autoCal
- Save screen to USB
- Adjustable zoom preview window

## OPTIONS

- Loading or exit rollerbeds
- Tropical humidity kit
- DVD drive
- Dual conveyor motors
- autoMatAlert
- autoZ display
- Image archiving (500K)
- Threat image projection (TIP)
- Built-in training
- Level 1, 2 and 3 networking
- Item counter
- Remote operation
- autoArchive
- User management
- Locking metal OCP cover
- Dual and larger monitors
- Locking monitor garage
- Laser printer
- Console desk
- kV, mA meter
- Power conditioner, or UPS
- Optical X-ray on/off sensor
- Footpad
- STI Viewer software for archived image analysis

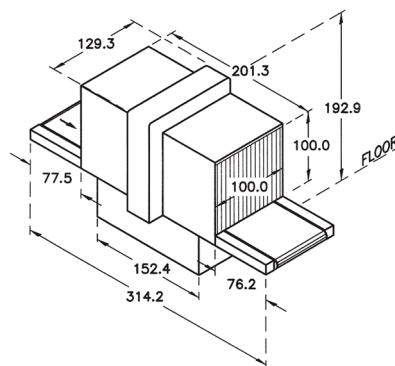

NOTE: Non-marking casters. Dimensions are in centimeters.